

Momentum & Energy Transport in the Wakes of Floating Turbines

Dylan Green*, Tim Rafferty, Markella Zormpa, Chris Vogel

dylan.green@eng.ox.ac.uk

Motivation

Floating wind turbine wakes are complex...

- ↑↑ Floating wakes exhibit motion-excited unstable modes¹⁻⁴
- ↑↑ Different motions generate distinct structure (meandering/pulsating)^{1,4}
- ↑↑ With differing resilience to ambient turbulence²



Roll-induced
meandering

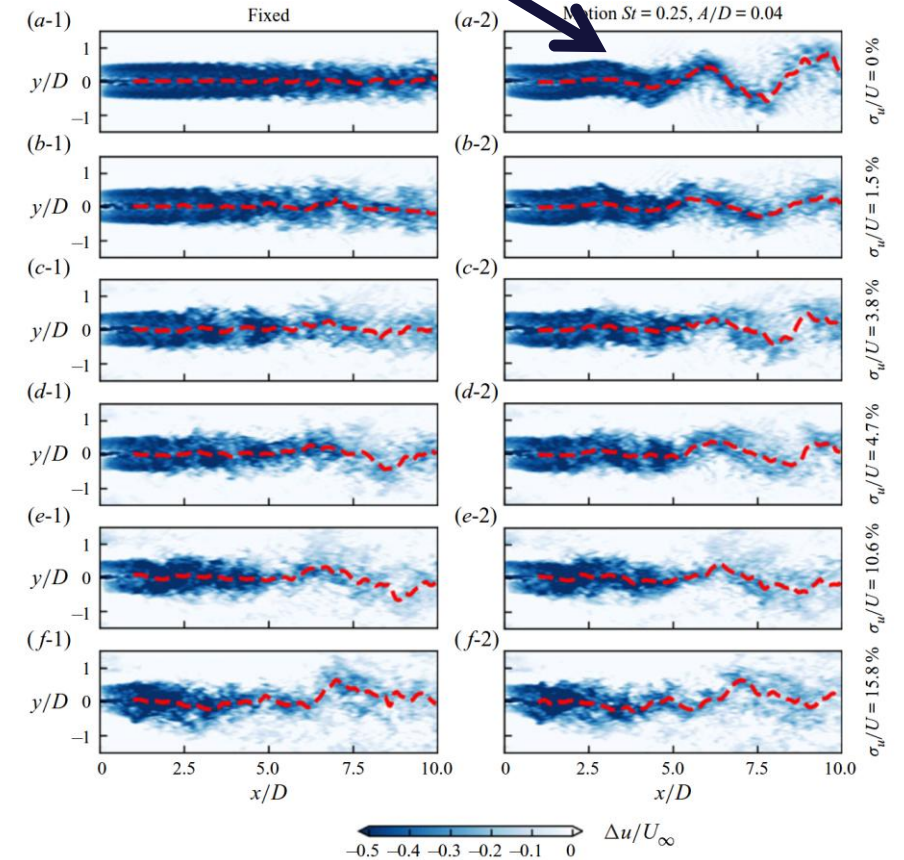

1. Messmer et al. 2024
 2. Messmer et al. 2025
 3. Li et al. 2024
 4. Li et al. 2022

Z. Li et al. "Onset of wake meandering for a floating offshore wind turbine under side-to-side motion". Journal of Fluid Mechanics. 2022

Motivation



How do these wake dynamics interact with their environment?

How do platform motions affect momentum/energy transport?

Methodology

Inflow

Inflow Cases:

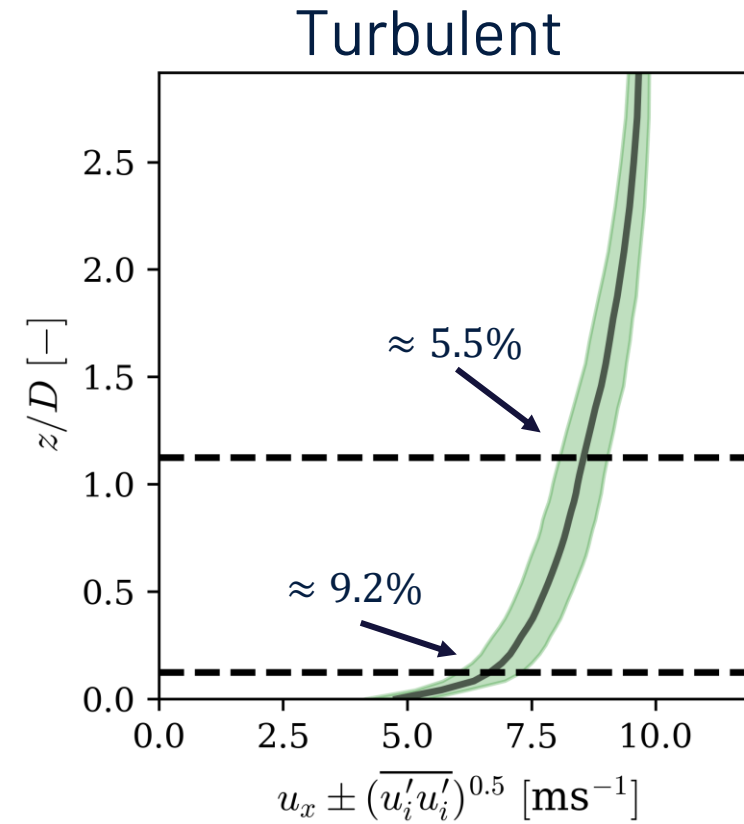
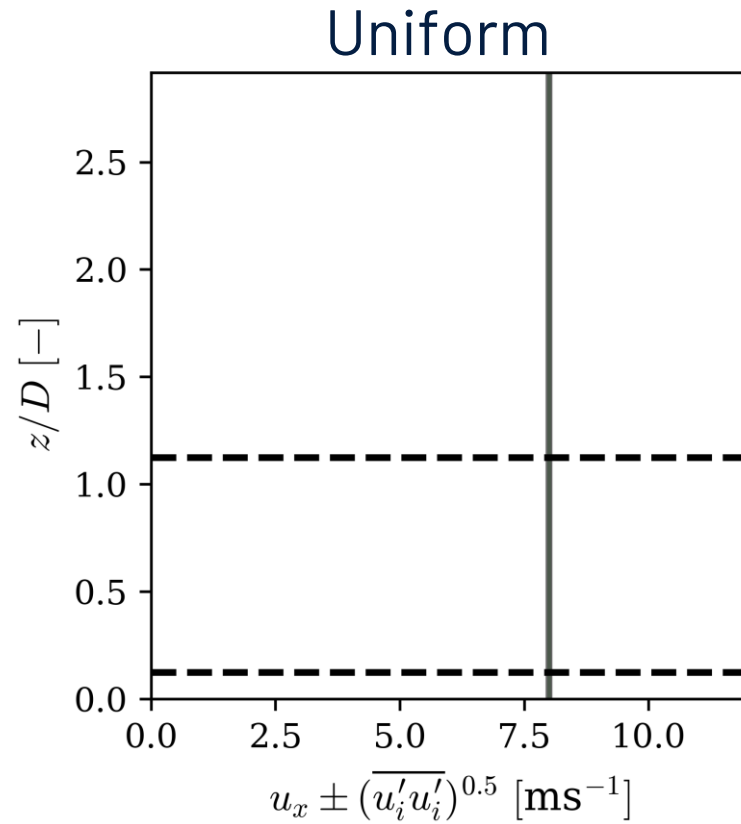

Methodology

Turbulence Generation:

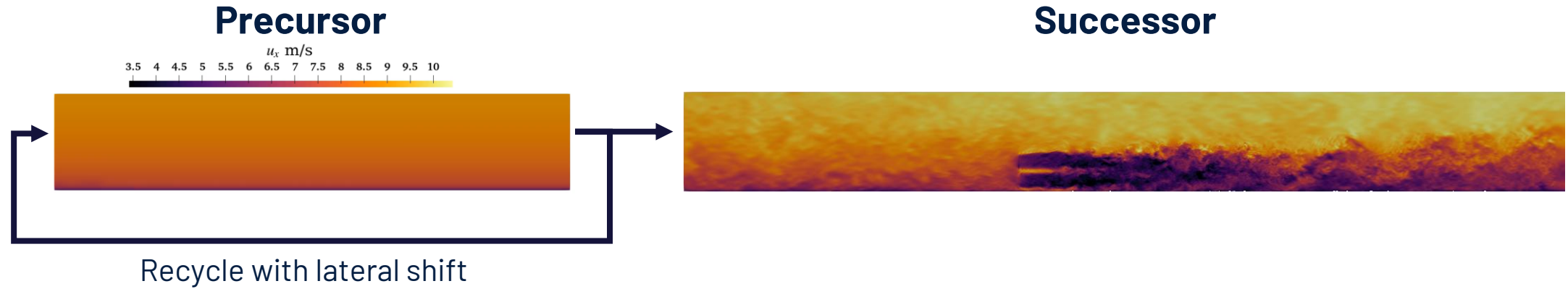

- †† OpenFoam v2212
- †† LES - Smagorinsky $C_s = 0.158$
- †† 2nd order spatial/temporal discretisation
- †† Schumann-Grotzbach stress, $z_0 = 0.001$

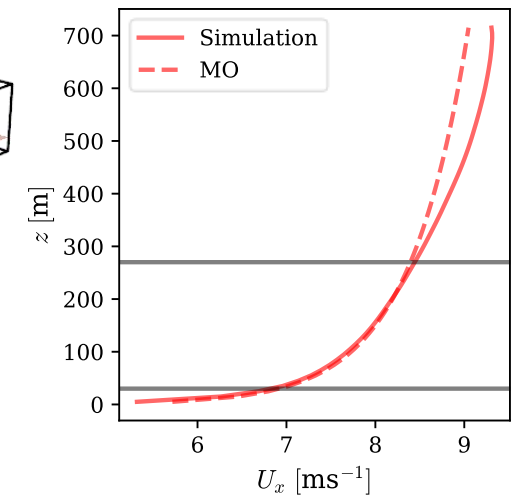
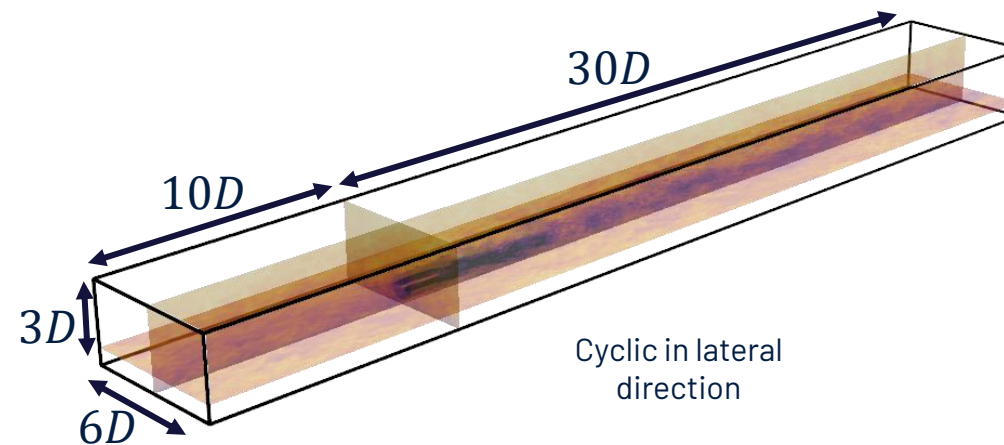

Methodology

Turbine Representation:

- †† IEA 15 MW
- †† Actuator line method
- †† Constant rot. speed, blade pitch
- †† Prescribed platform motions

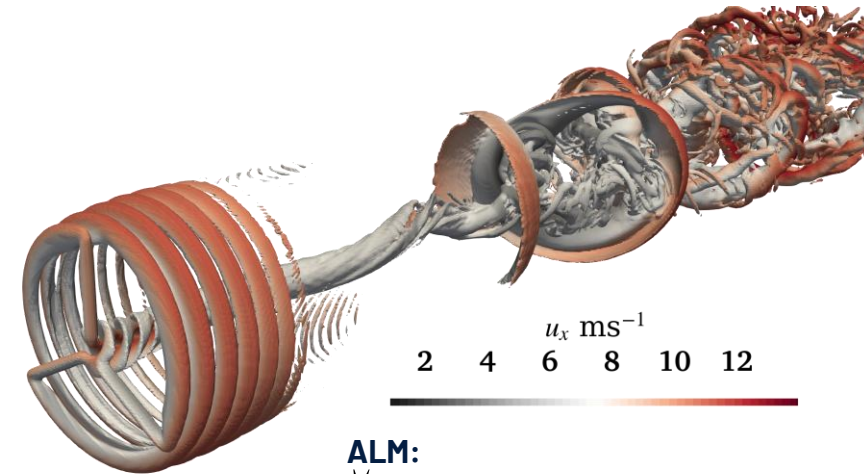

ALM:

- †† Line average sampling
- †† 75 collocation points
- †† Previously validated for fixed/floating wind/tidal¹⁻³
- †† 3D spherical Gaussian regularisation kernel

Motion Settings:

Fixed:

- †† $f_p^* = -$
- †† $A_p = -, A_p^* = -$
- †† $\Delta U^* = -$

Pitch:

- †† $f_p^* = 0.72$
- †† $A_p = 2.5^\circ, A_p^* = 0.027$
- †† $\Delta U^* = 0.123$

Roll:

- †† $f_p^* = 0.32$
- †† $A_p = 2.5^\circ, A_p^* = 0.027$
- †† $\Delta U^* = 0.054$

1. Wimshurst A and Willden R H J 2017 Wind Energy 20 815–833
2. Willden R et al. 2023 Proceedings of the European wave and tidal energy conference vol 15
3. Green D, Zormpa M and Vogel C 2025 11th Conference on Computational Methods in Marine Engineering

Results

J. Fluid Mech. (2013), vol. 715, pp. 335–358. © Cambridge University Press 2013
doi:10.1017/jfm.2012.523

335

Flow visualization using momentum and energy transport tubes and applications to turbulent flow in wind farms

Johan Meyers^{1,†} and Charles Meneveau²

¹Department of Mechanical Engineering, KU Leuven, Celestijnenlaan 300A, B3001 Leuven, Belgium

²Department of Mechanical Engineering and Center for Environmental and Applied Fluid Mechanics, Johns Hopkins University, 3400 North Charles Street, Baltimore, MD 21218, USA

(Received 10 July 2012; revised 14 October 2012; accepted 17 October 2012)

As a generalization of the mass–flux based classical stream tube, the concept of momentum and energy transport tubes is discussed as a flow visualization tool. These transport tubes have the property that no fluxes of momentum or energy exist over their respective tube mantles. As an example application using data from large eddy simulation, such tubes are visualized for the mean-flow structure of turbulent flow in large wind farms, in fully developed wind-turbine-array boundary layers. The three-dimensional organization of energy transport tubes changes considerably when turbine spacings are varied, enabling the visualization of the path taken by the kinetic energy flux that is ultimately available at any given turbine within the array.

Key words: turbulent flows

J. Meyers and C. Meneveau. *Journal of Fluid Mechanics*. 2013

Analysis Methodology

A **stream tube** is a bundle of streamlines in a fluid flow that forms a tube-like region where no fluid crosses its boundaries.

† Create a streamline

A curve everywhere tangent to the local fluid velocity.

$$\Gamma = \{ \mathbf{x}(s) : s \in \mathbb{R}, \mathbf{x}(s) \times \bar{\mathbf{u}} = \mathbf{0} \}$$

† Stitch together streamlines into a stream tube...

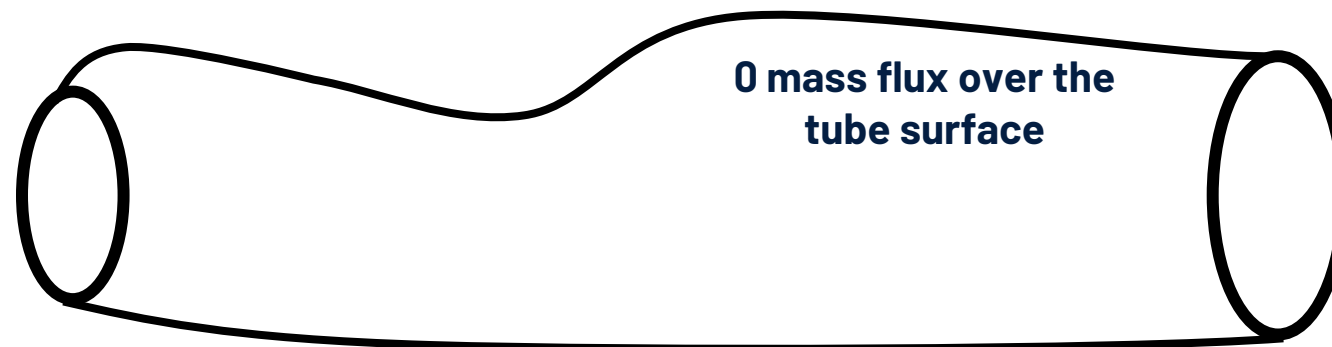

mass in = mass out

Analysis Methodology

† Take momentum equation

$$\frac{Du_j}{Dt} = -\frac{1}{\rho} \frac{\partial p}{\partial x_j} + \nu \frac{\partial^2 u_j}{\partial x_i \partial x_i} + f_j^{\text{ALM}} + f_j^\infty$$

† Write in conservative form

$$\partial_j \underbrace{\Phi_j^{\bar{u} \cdot \zeta}}_{\substack{\uparrow \\ \text{Flux of } \zeta\text{-momentum}}} = \underbrace{Q^{\bar{u} \cdot \zeta}}_{\substack{\uparrow \\ \text{Sources of } \zeta\text{-momentum}}}$$

† Define a ζ -momentum velocity

$$u_j^{\bar{u} \cdot \zeta} = \frac{\Phi_j^{\bar{u} \cdot \zeta}}{\bar{u} \cdot \zeta} = \bar{u}_j + \frac{\left(\overline{u'_i u'_j} + \bar{\tau}_{ij}^d - 2\nu \bar{S}_{ij} \right) \zeta_i}{(\bar{u}_k \zeta_k)}$$

Analysis Methodology

↑ Construct axial-momentum tubes

$$u_j \bar{u} \cdot \zeta = \bar{u}_j + \frac{(\overline{u'_i u'_j} + \bar{\tau}_{ij}^d - 2\nu \bar{S}_{ij}) \zeta_i}{(\bar{u}_k \zeta_k)}$$

$$u_j^E = \bar{u}_j + \frac{(\overline{u'_i u'_j} + \bar{\tau}_{ij}^d - 2\nu \bar{S}_{ij}) \bar{u}_i}{E}$$

Mass Tube

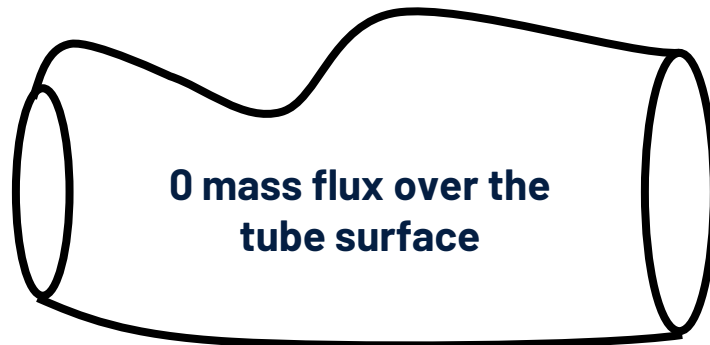

mass in = mass out

Axial Momentum Tube



axial momentum in = axial momentum out + integrated sources

Mechanical Energy Tube

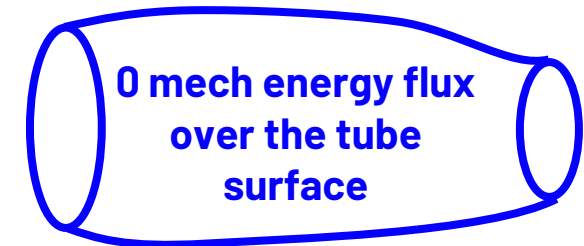

mech energy in = mech energy out + integrated sources

Transport Tubes

Tube Cross Sections

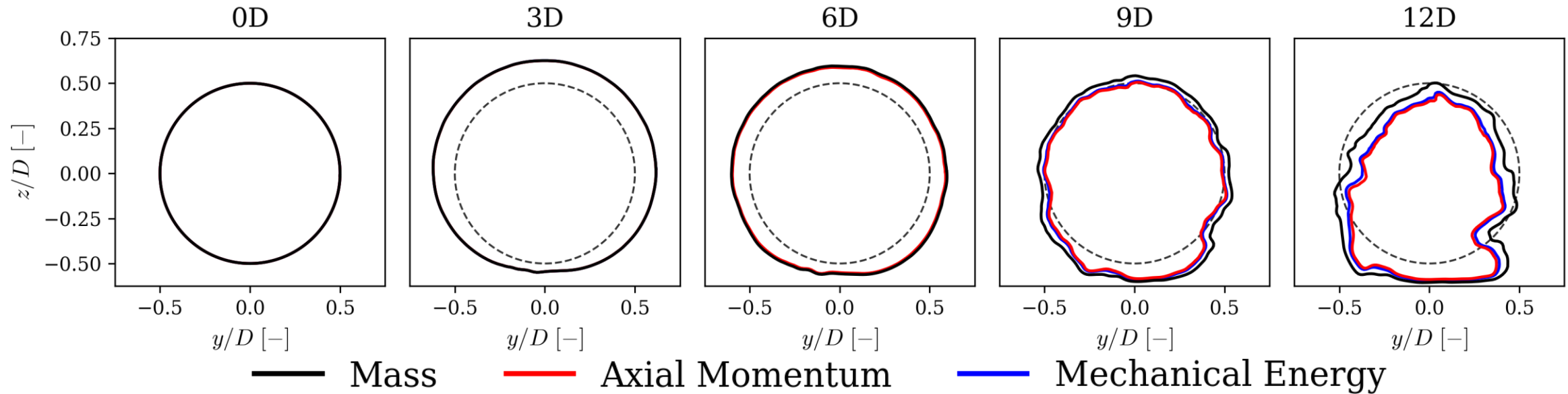

**Fixed Turbine in
uniform inflow**

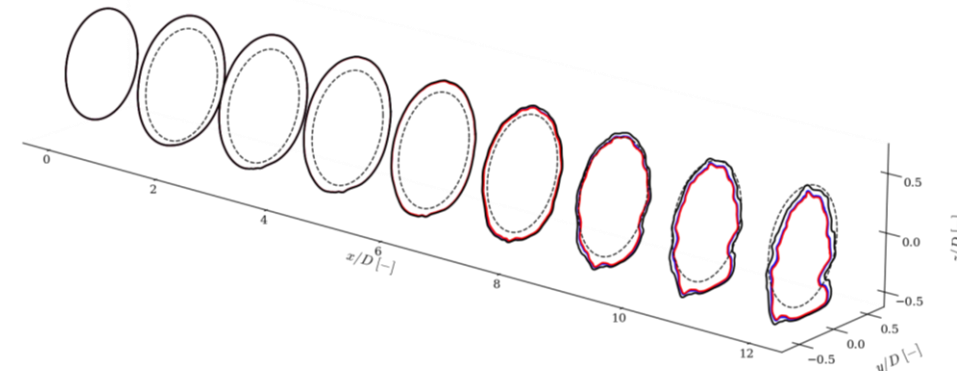

Transport Tubes

Fixed Turbine in uniform inflow

Tube Cross Sections

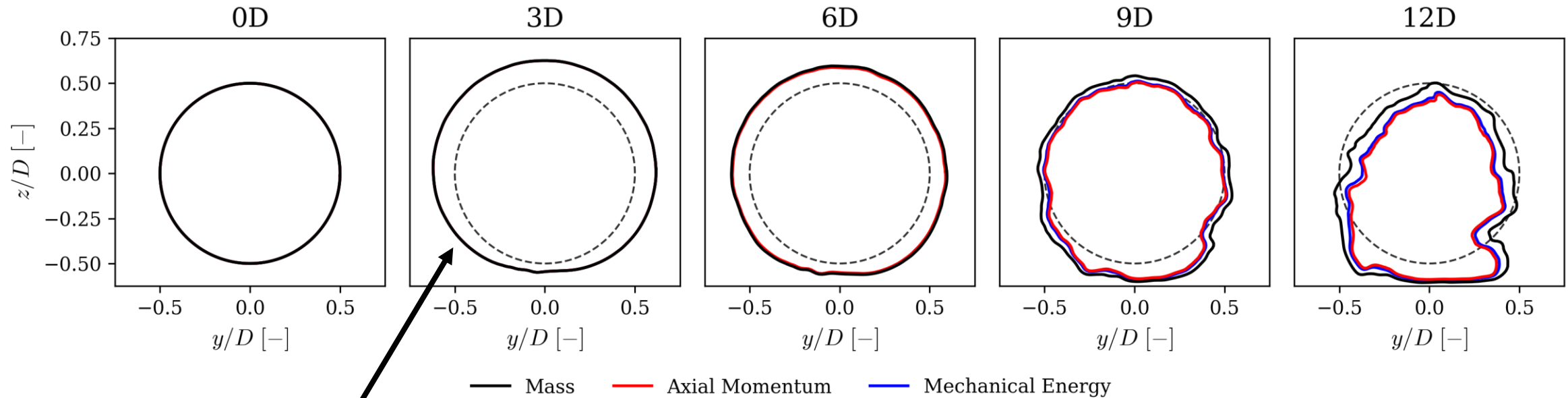

Expansion of tubes due
velocity deficit

Transport Tubes

Fixed Turbine in uniform inflow

Tube Cross Sections

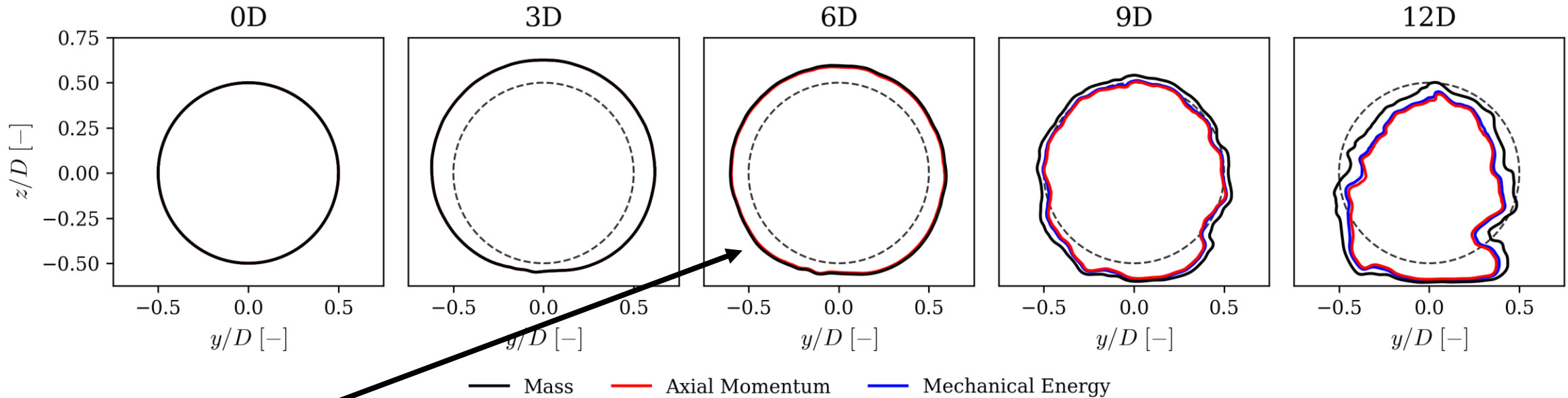

Tubes remain coincident

Wake remains stable at 6D resulting in insignificant momentum/energy exchange

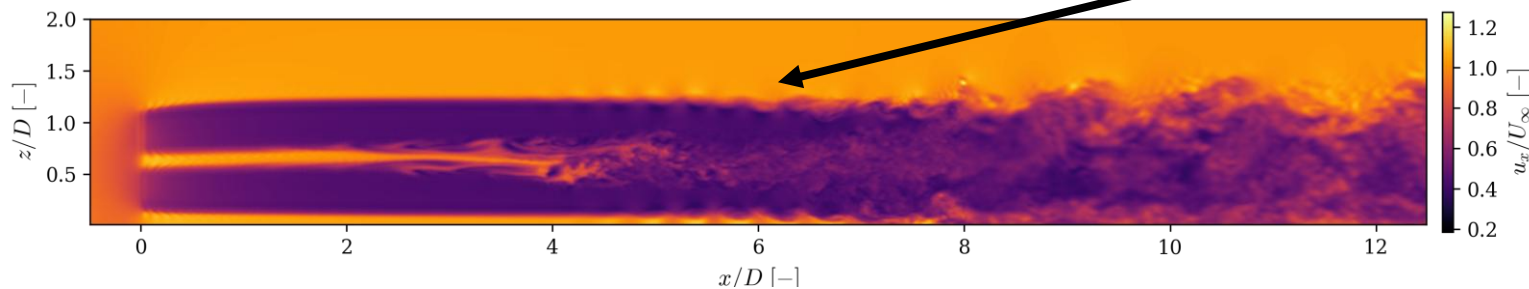

Transport Tubes

Fixed Turbine in uniform inflow

Tube Cross Sections

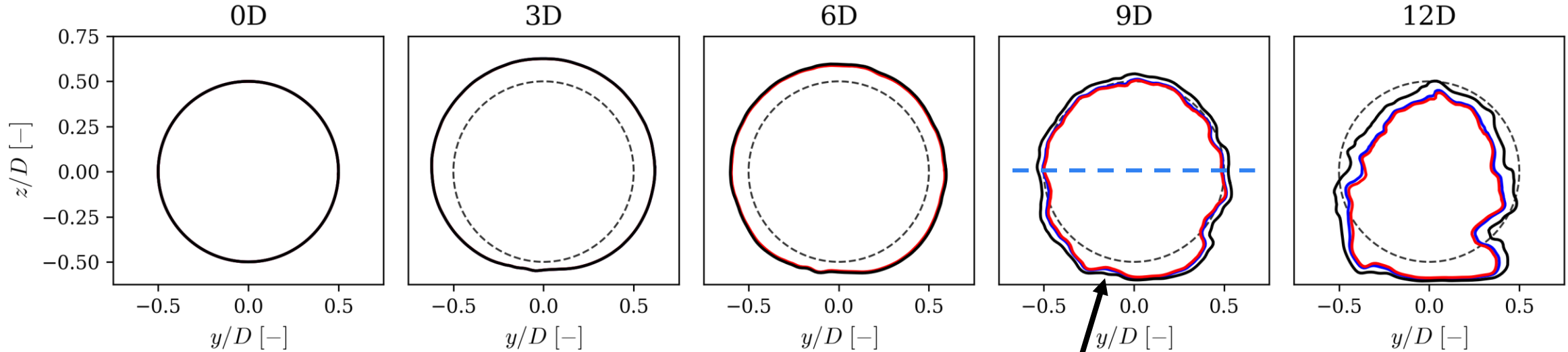

— Mass — Axial Momentum — Mechanical Energy

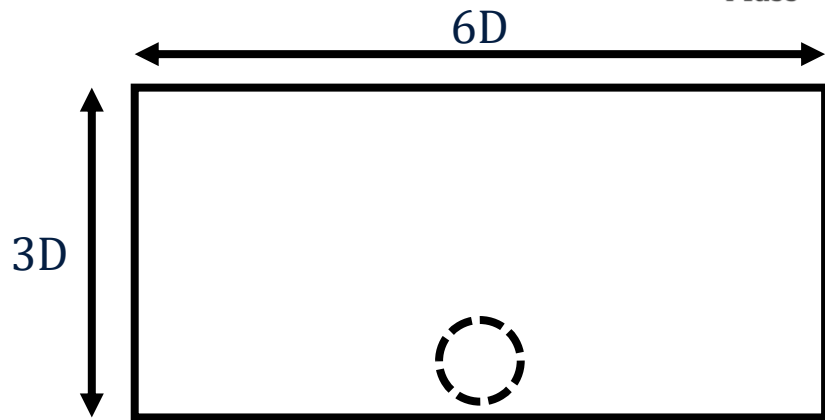

Local blockage generates
asymmetry in cross section

Transport Tubes

Fixed Turbine in uniform inflow

Tube Cross Sections

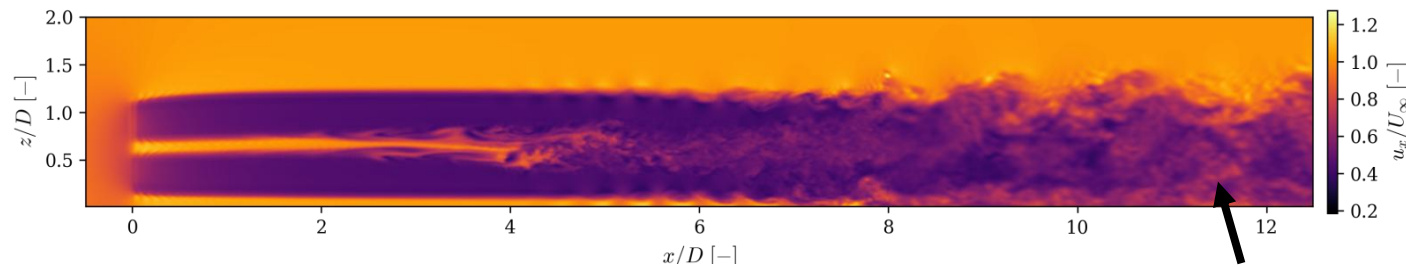
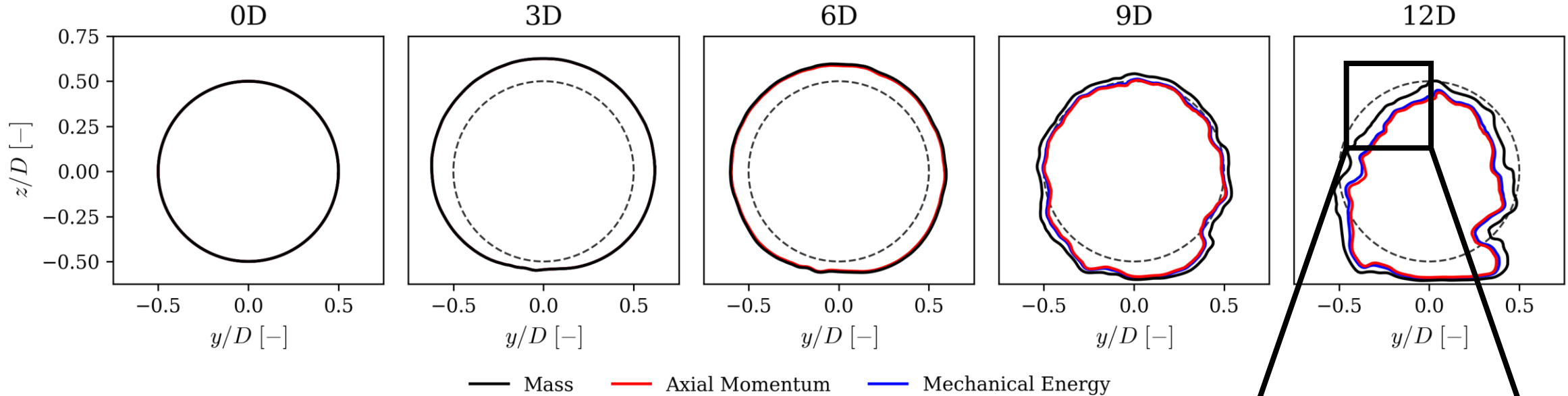

Breakdown transports
energy/momentum

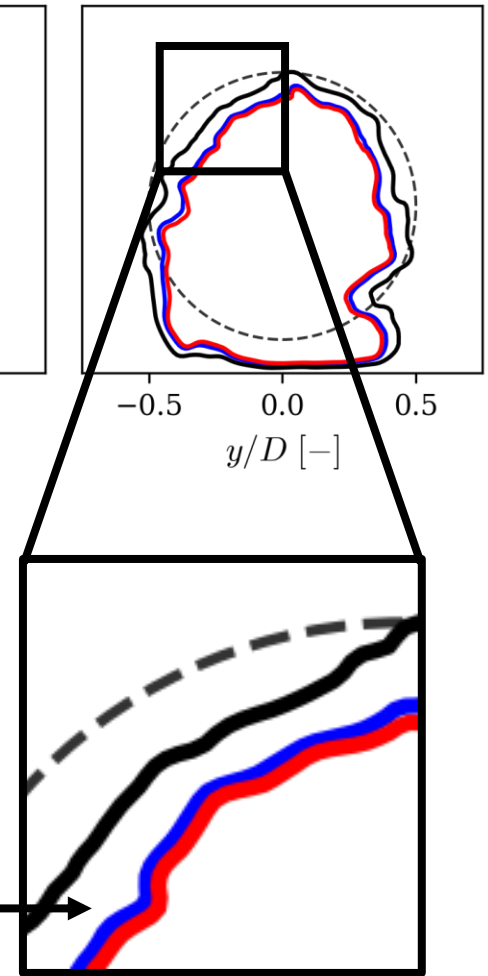

Transport Tubes

Fixed Turbine in uniform inflow

Tube Cross Sections

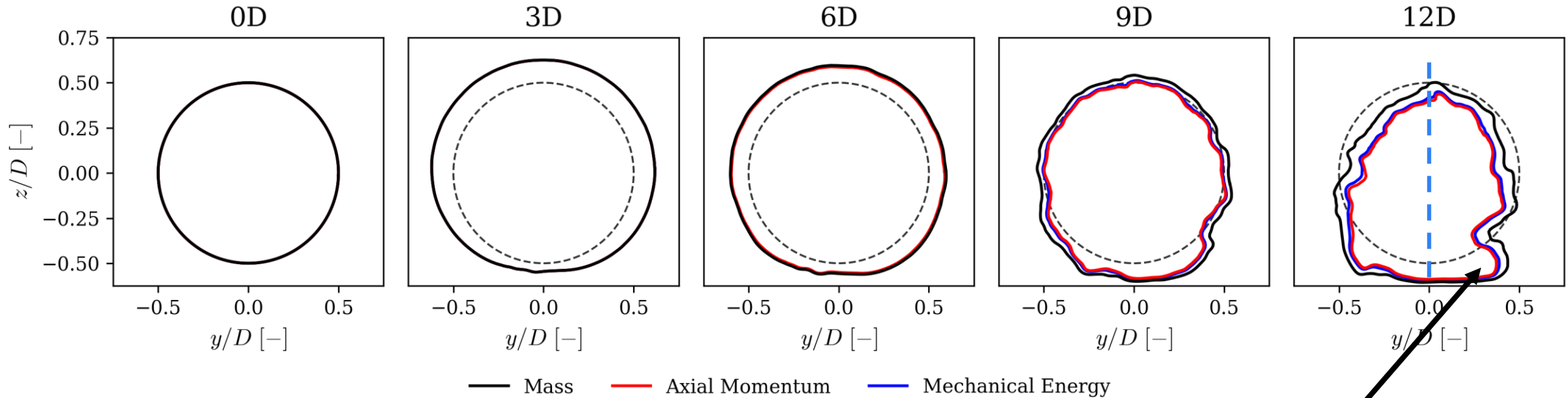

Wake rotation interacts with local blockage creating further asymmetry

Q1: How do floating motions affect this?

Pitching Turbine & Transport Tubes



Pitching Turbine in uniform inflow

Tube Cross Sections

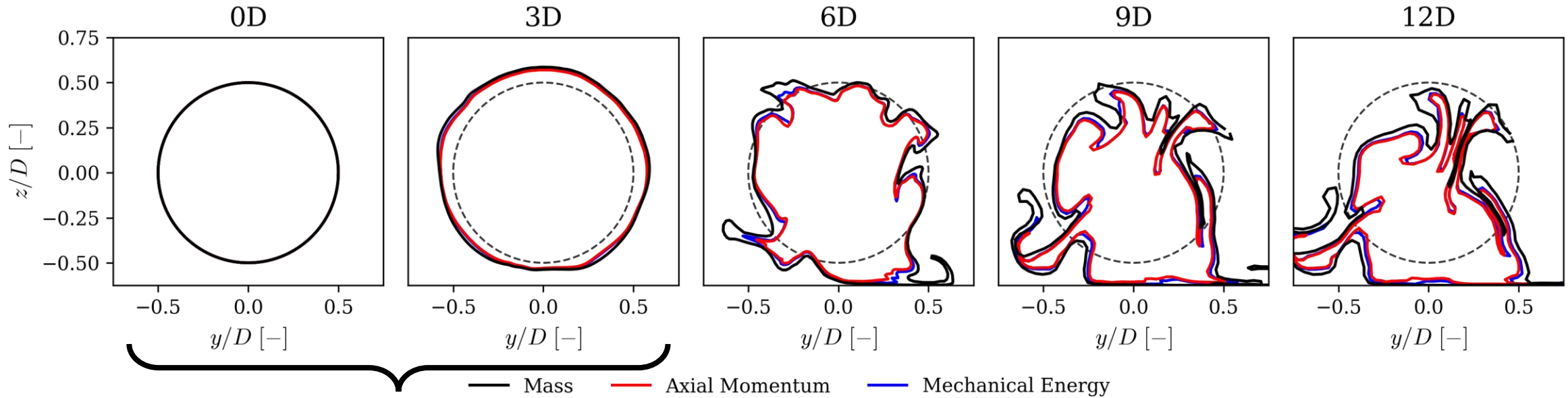

Near wake tubes remain
approx. unchanged

Pitching Turbine & Transport Tubes



Pitching Turbine in uniform inflow

Tube Cross Sections

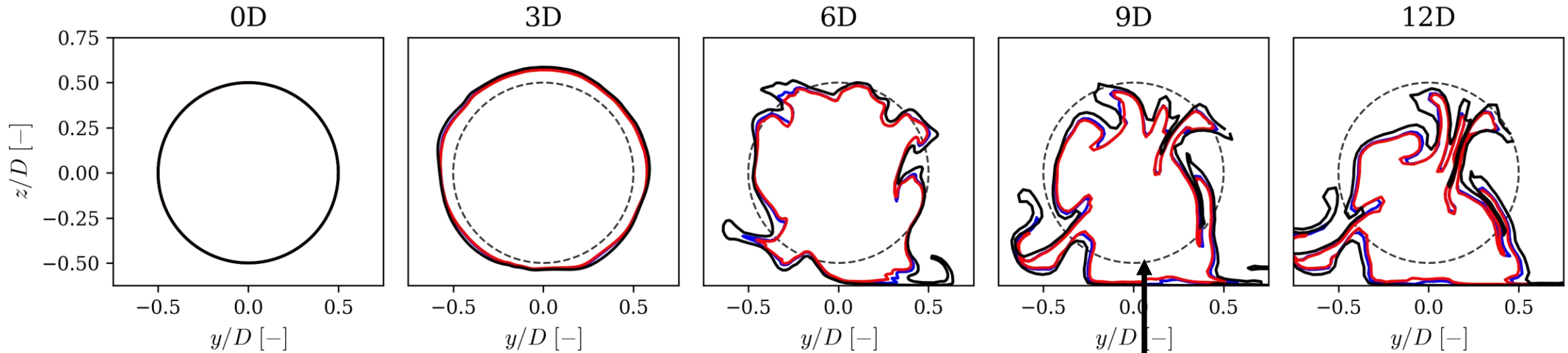

z-Component of axial momentum velocity at 7D

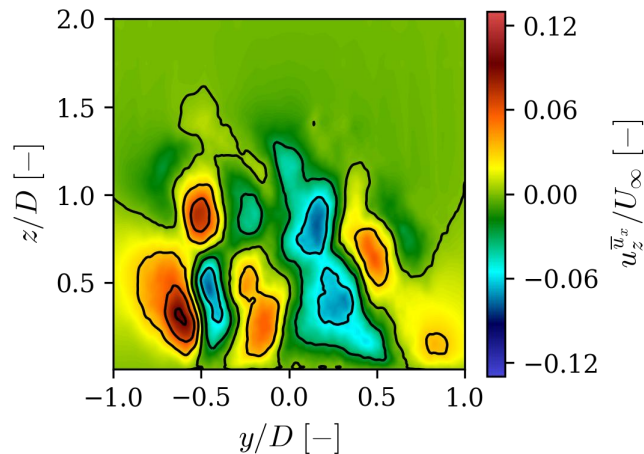

Complex pitch-induced coherent structures significantly modify transport of mass and momentum

Pitching Turbine & Transport Tubes

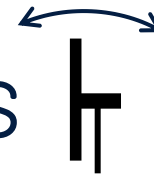

Pitching Turbine in uniform inflow

Tube Cross Sections

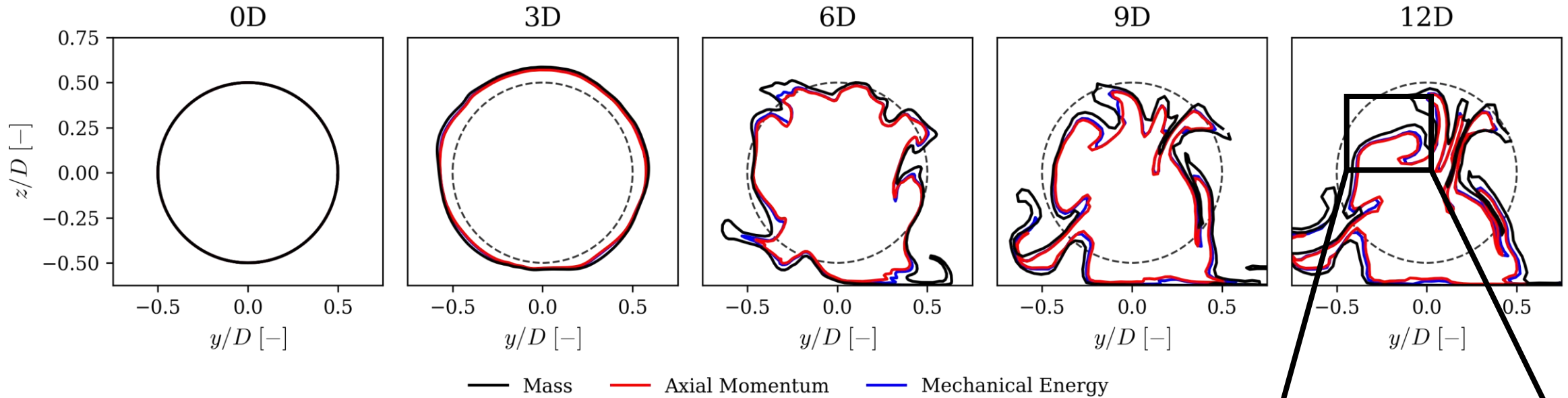

Despite complex motions, differences between not significantly affected

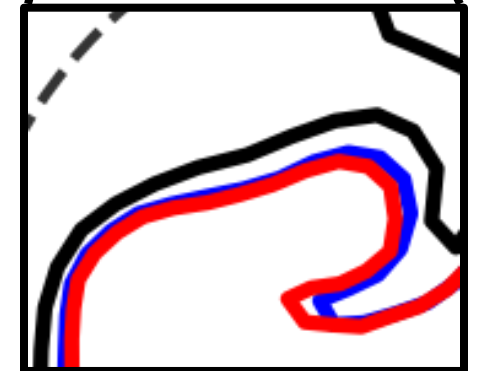

Rolling Turbine & Transport Tubes



Rolling Turbine in uniform inflow

Tube Cross Sections

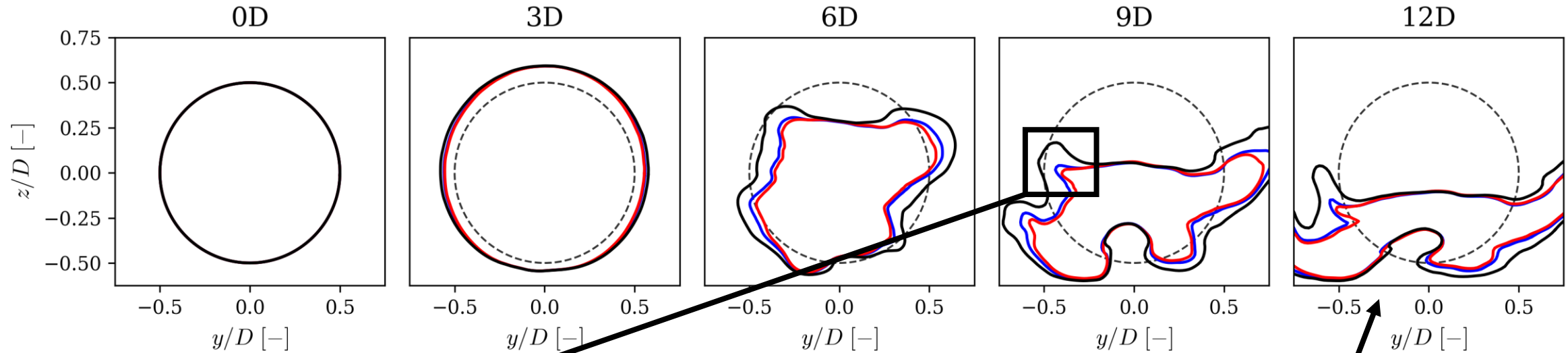

— Mass — Axial Momentum — Mechanical Energy

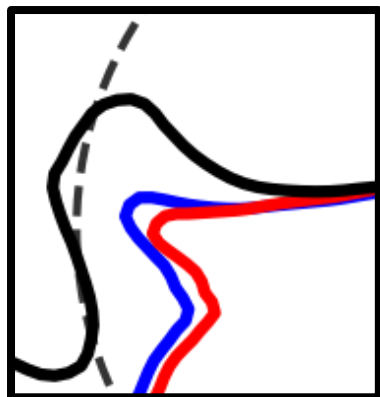

Increased differences between tubes suggests enhanced entrainment

Large lateral spread of mass/momentum/energy

Significant vertical shift

The Effect of Motions in Uniform Inflow



- Fixed
- Pitch
- Roll

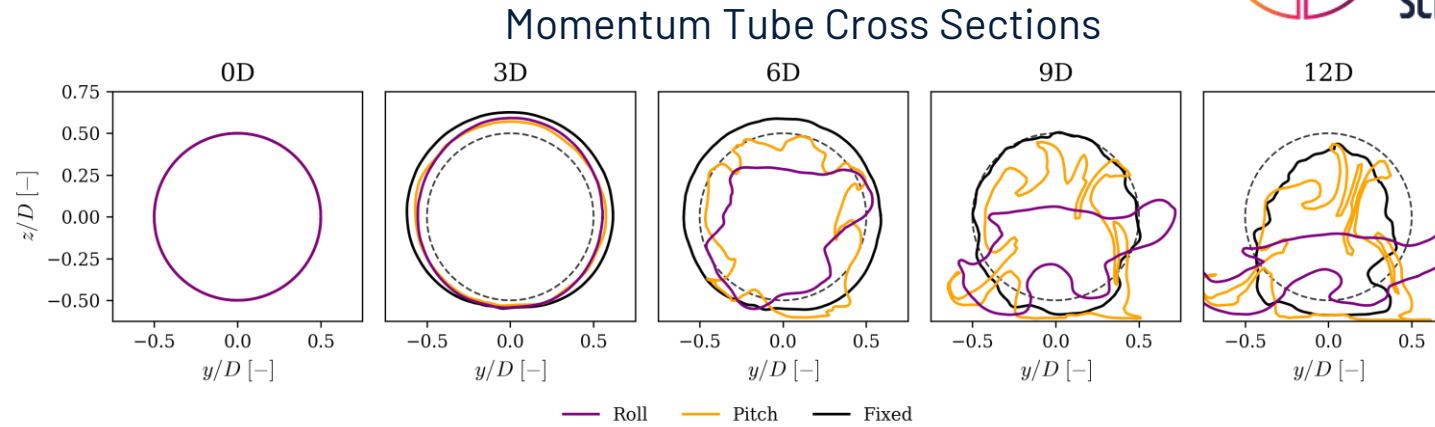

Compare 0th, 1st, 2nd moments of cross sections...

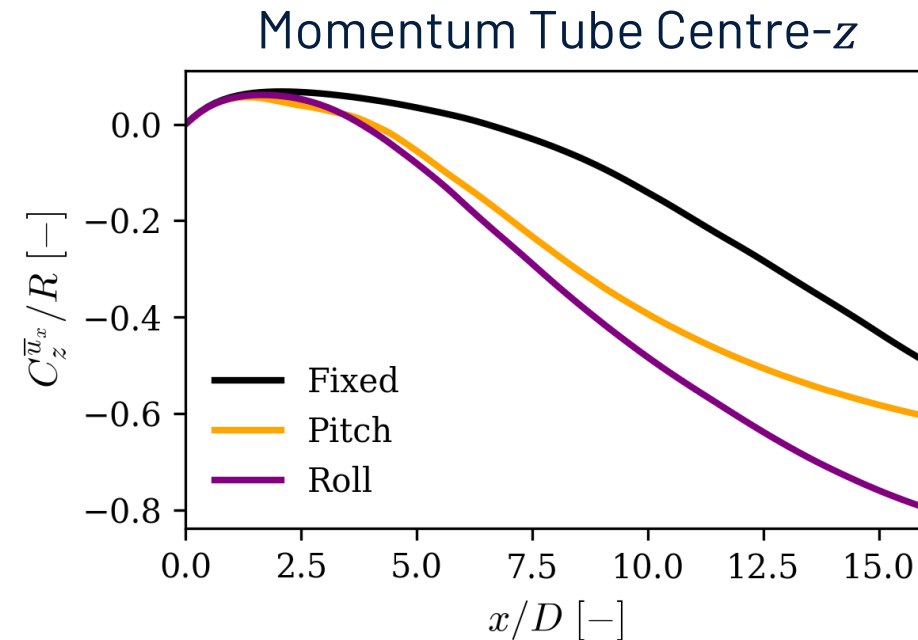
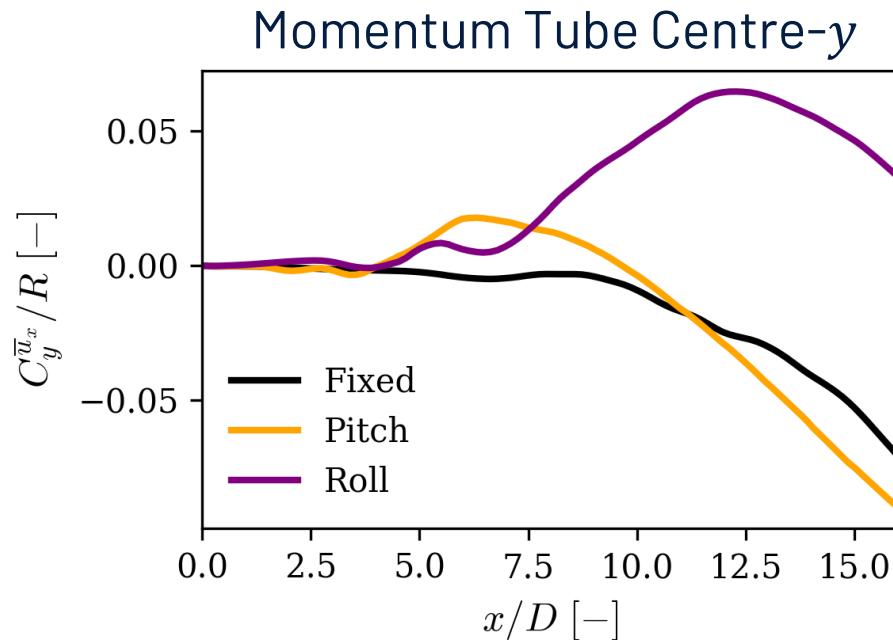

The Effect of Motions in Uniform Inflow



- Fixed
- Pitch
- Roll

Momentum Tube Cross Sections

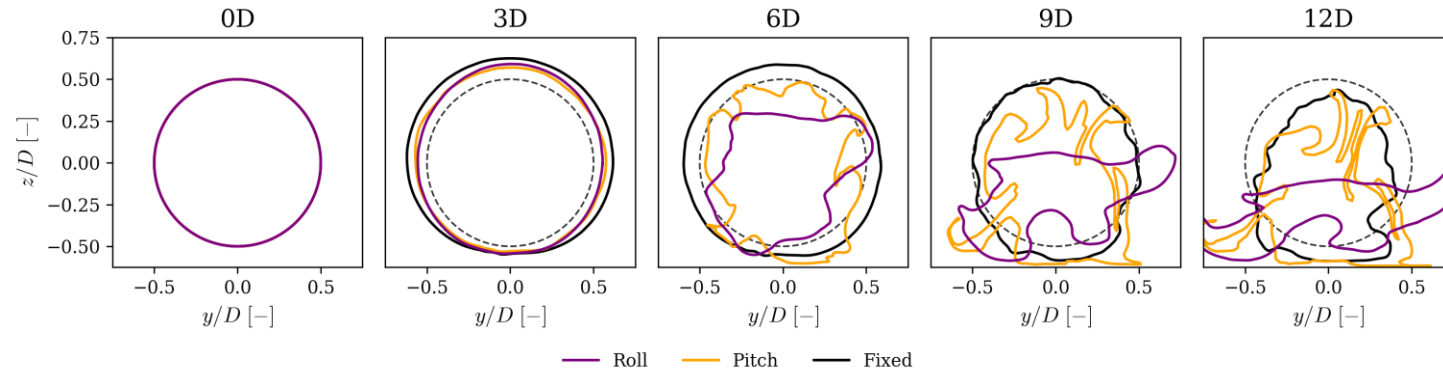

Momentum Tube Width-y

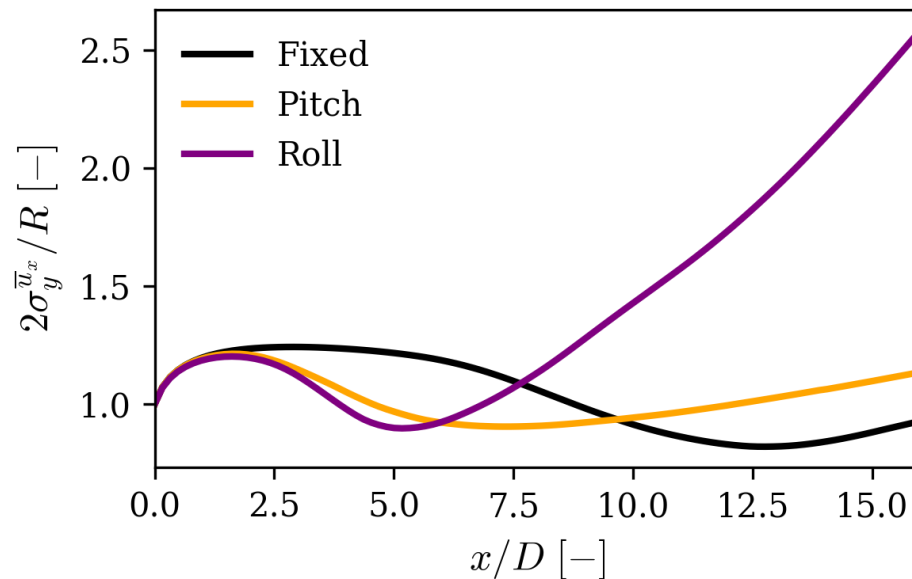

Momentum Tube Width-z

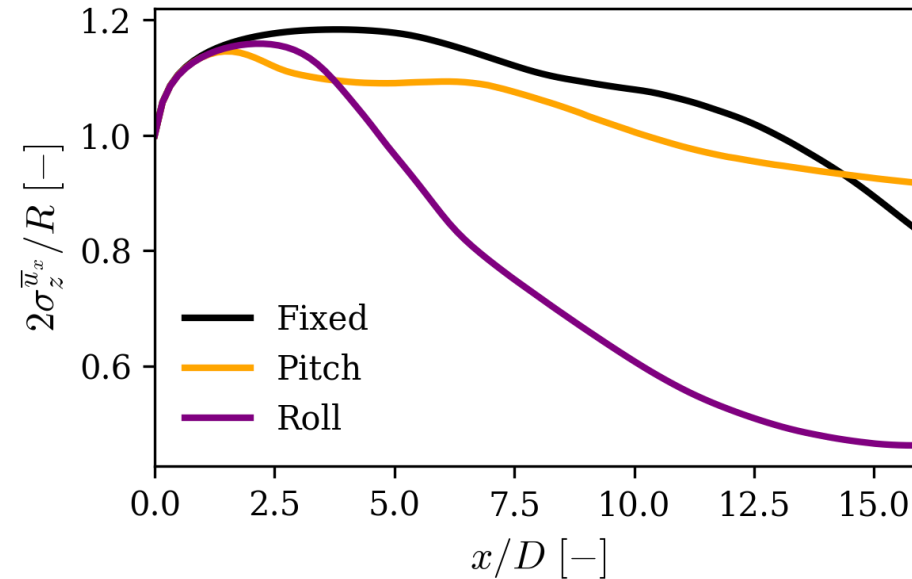

The Effect of Motions in Uniform Inflow

- Fixed
- Pitch
- Roll

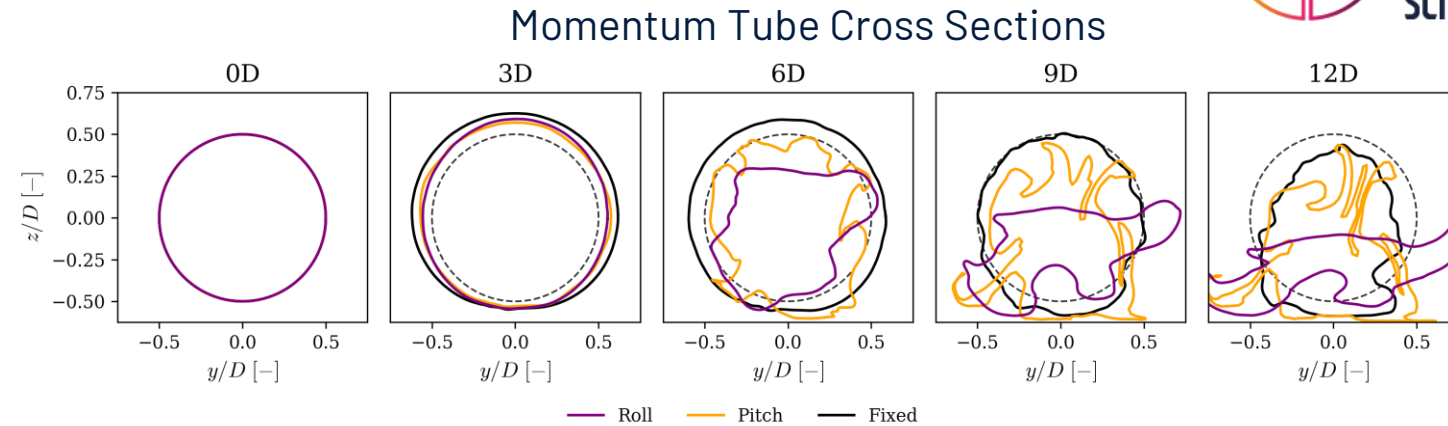

Momentum tube cross sectional area significantly reduced beyond the near wake

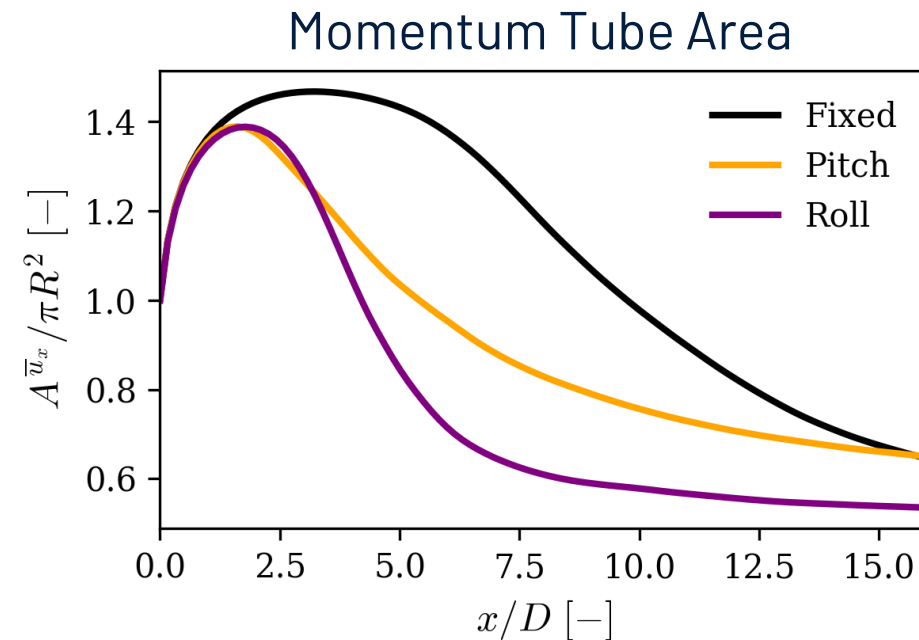

Q2: How does inflow affect this?

Turbines In Turbulent Flow

Momentum Tube Cross Sections

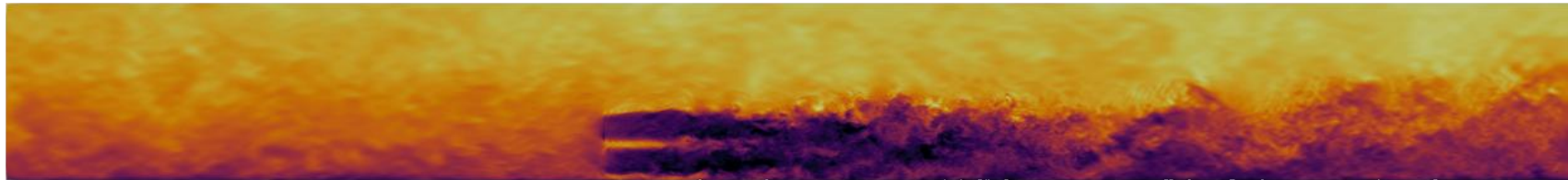
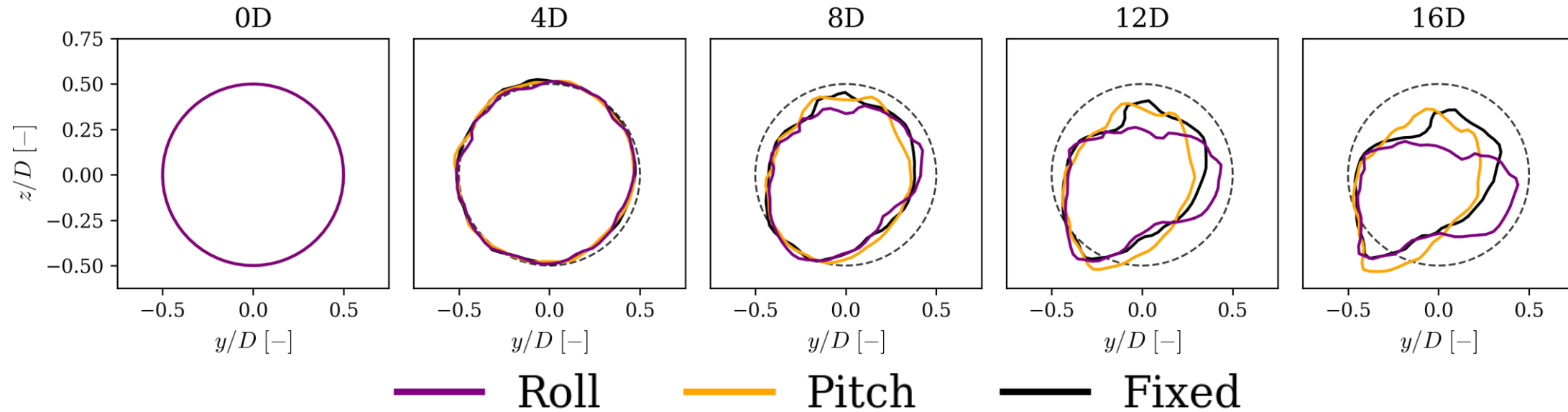

Turbines In Turbulent Flow

Momentum Tube Cross Sections

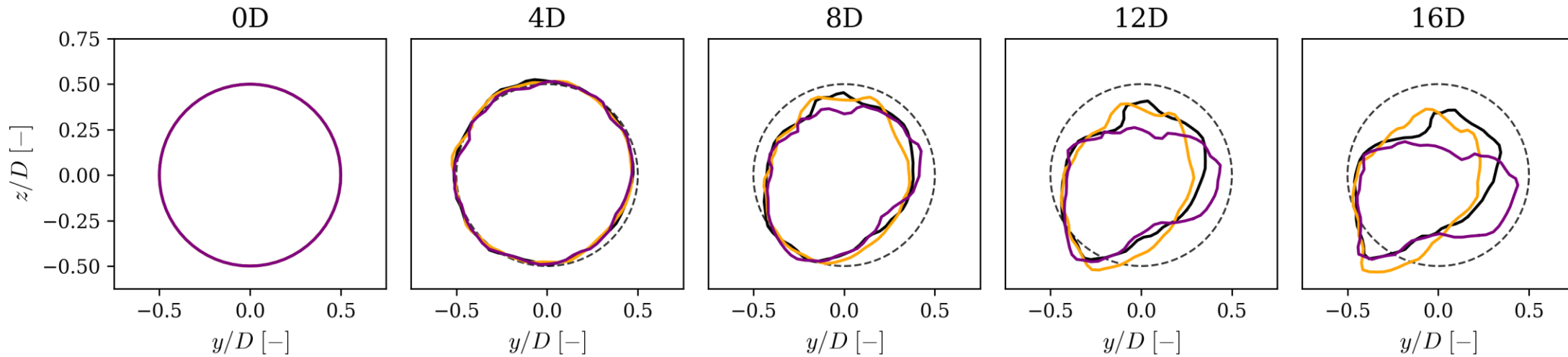

Roll Pitch Fixed

Momentum Tube Area

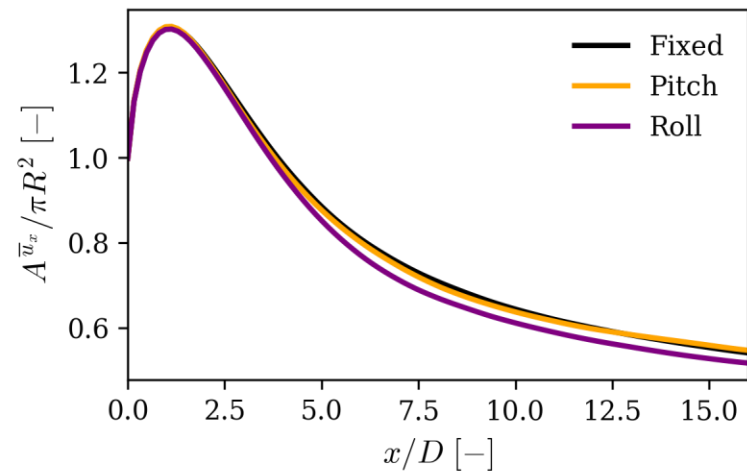

Sensitivity to motions heavily reduced.

Rolling motions retain some impact.

Turbines In Turbulent Flow

Momentum Tube Centre-y

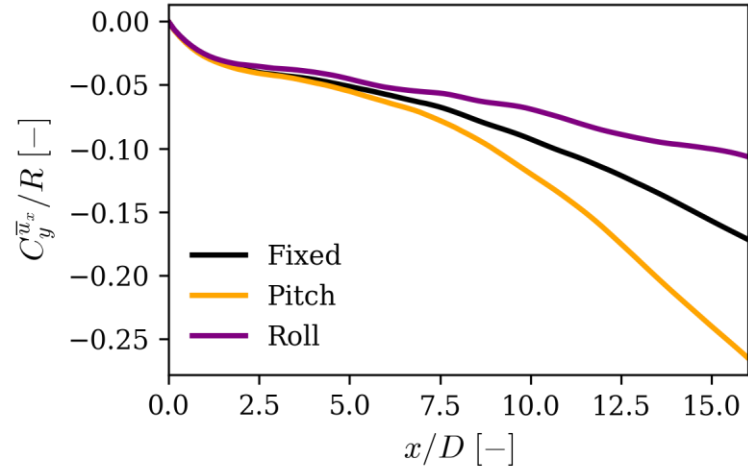

Momentum Tube Centre-z

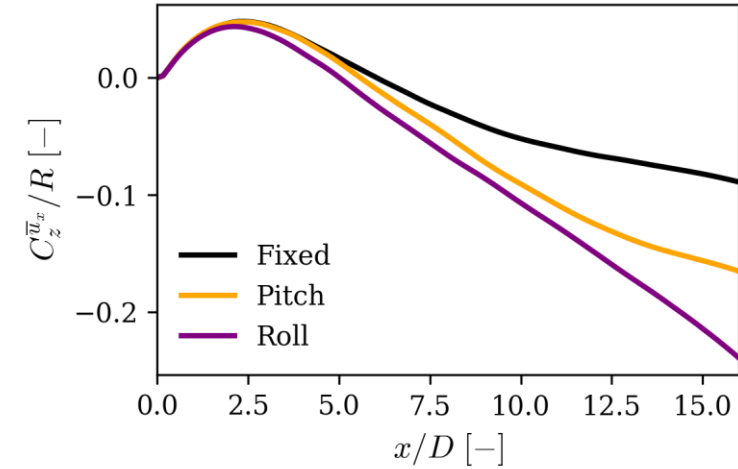

Momentum Tube Width-y

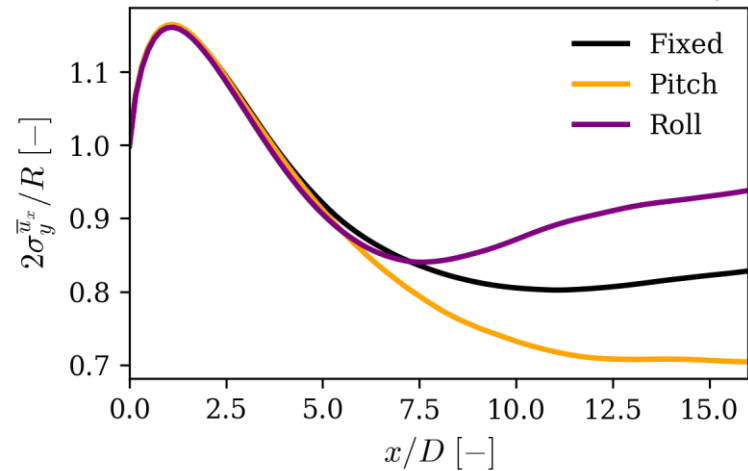

Momentum Tube Width-z

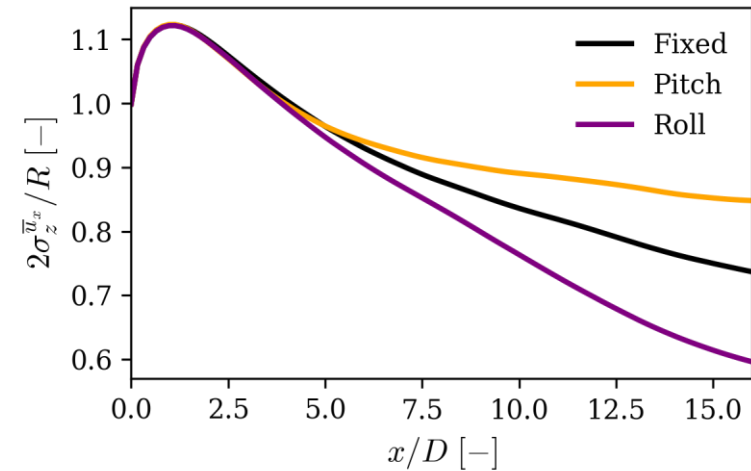

Turbines In Turbulent Flow

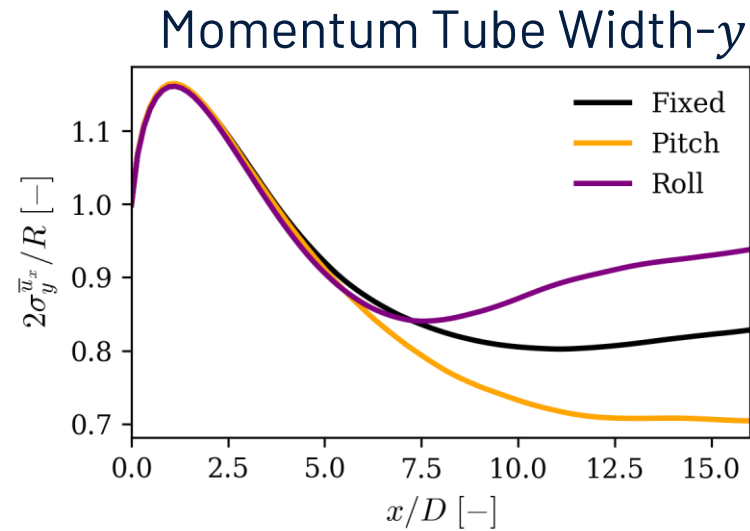
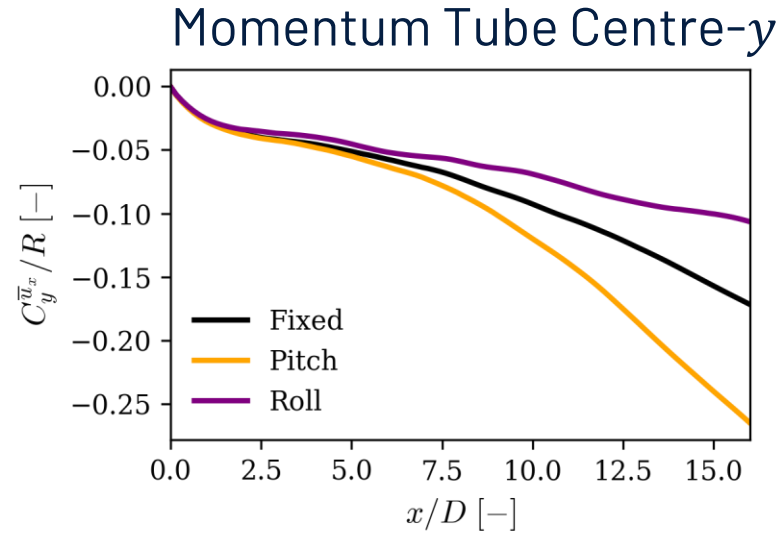

Momentum Tube Centre-z



Both tube width/centre remain dependent on platform motions

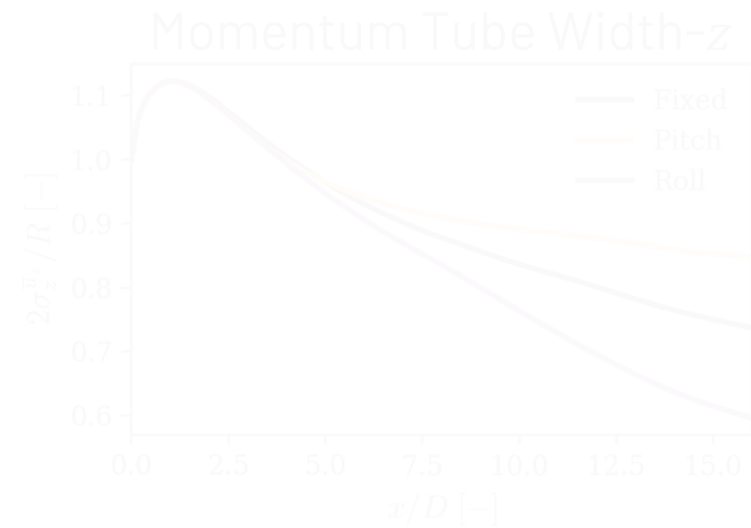

Q3: What is the influence of turbine spacing?

Turbine Spacing

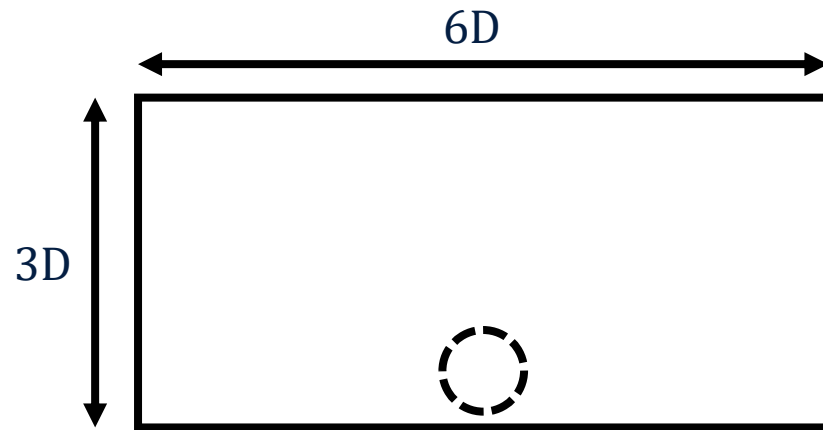

Vs

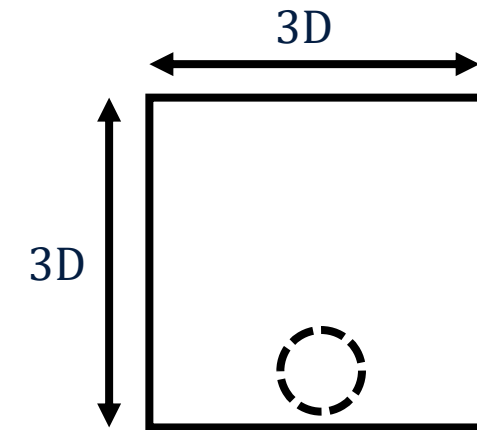

The Influence of Spacing

--- 3D
— 6D

Areas not significantly affected
by reduced rotor spacing

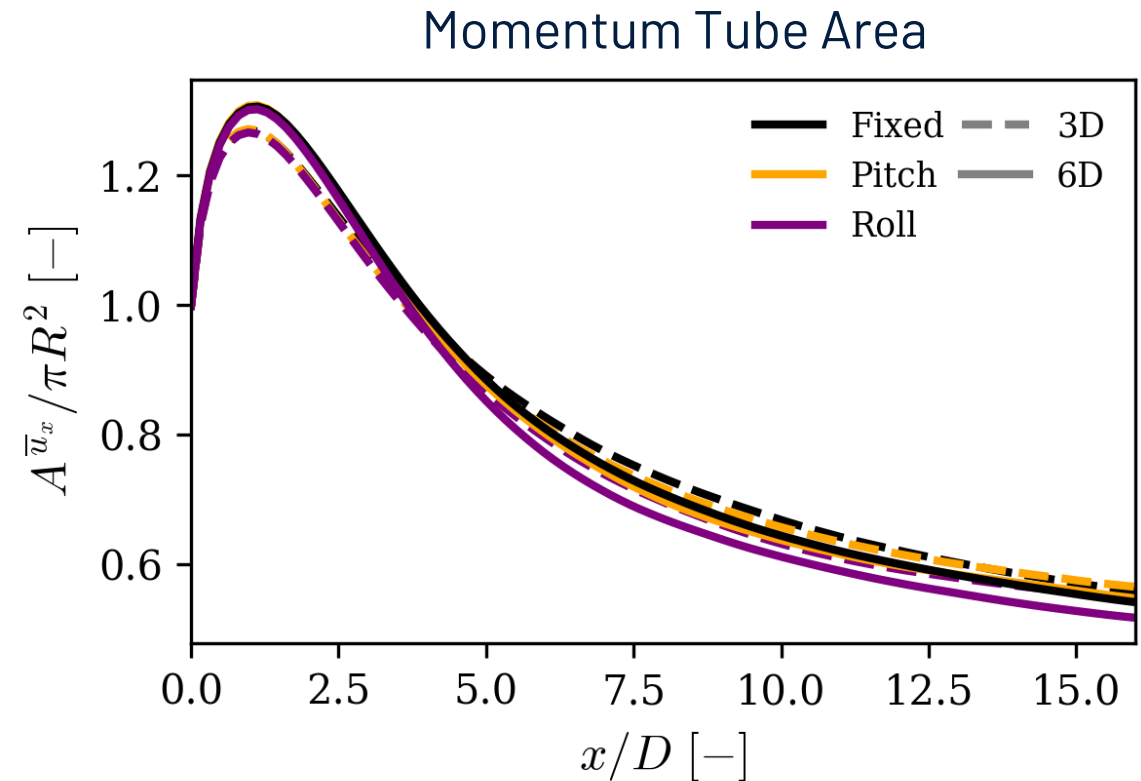

The Influence of Spacing

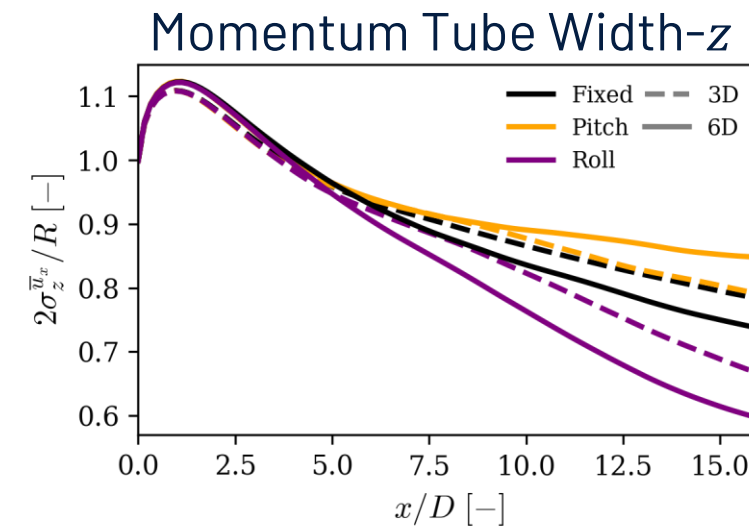
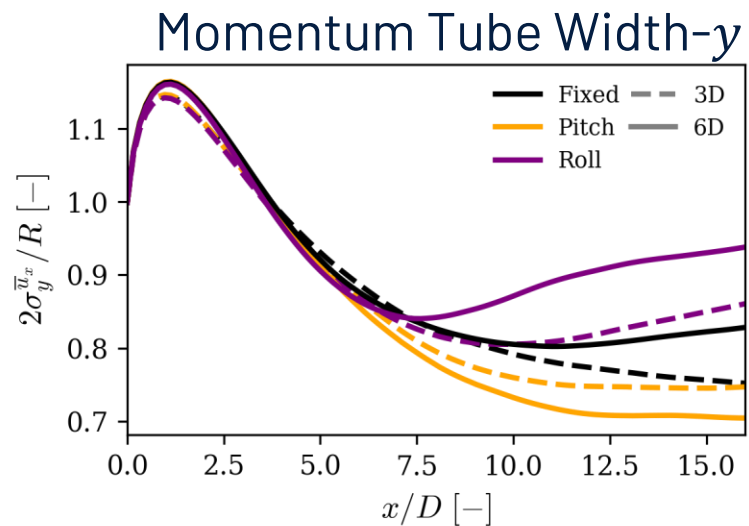
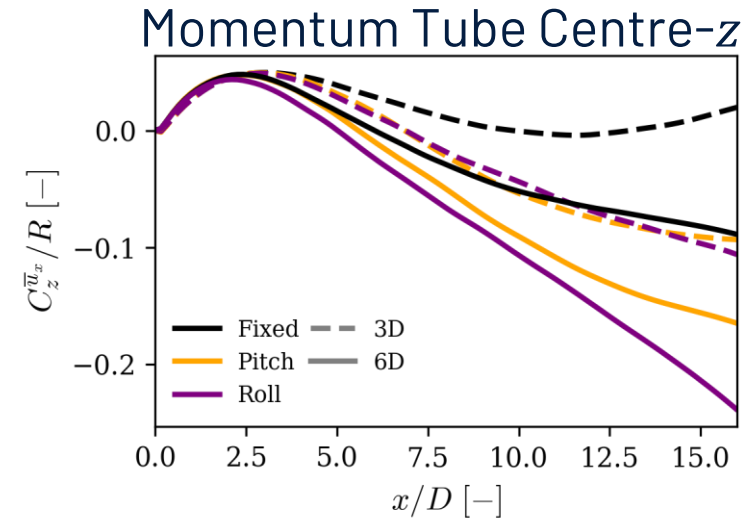
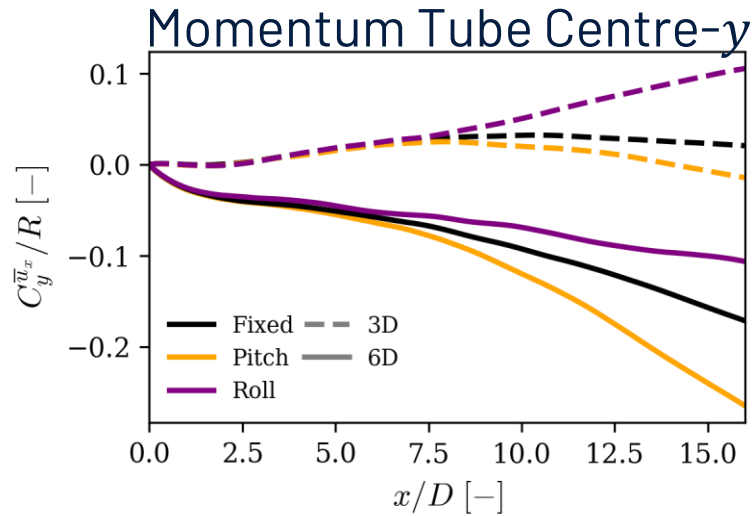

The Influence of Spacing

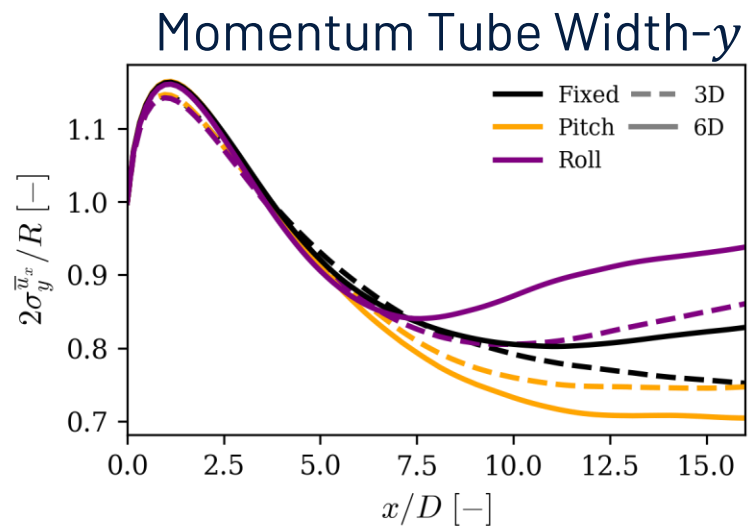
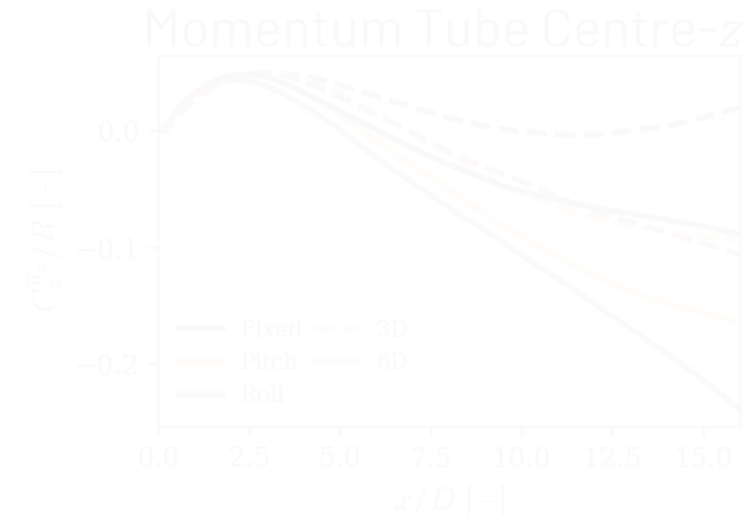
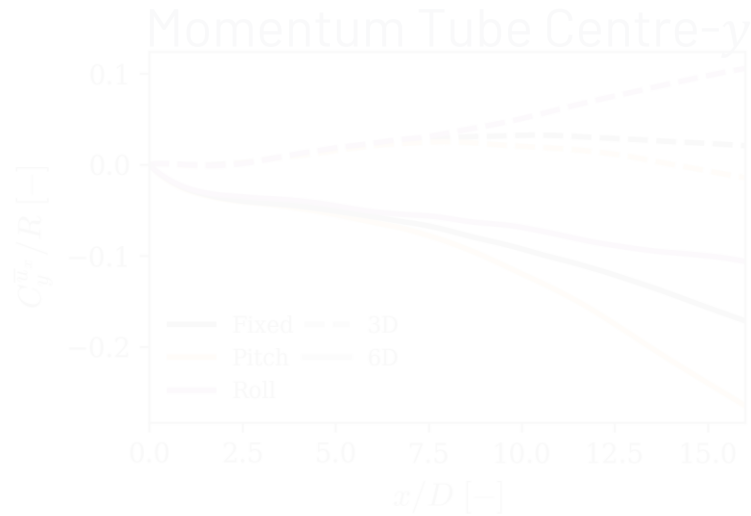

Roll/pitch affected
oppositely by spacing

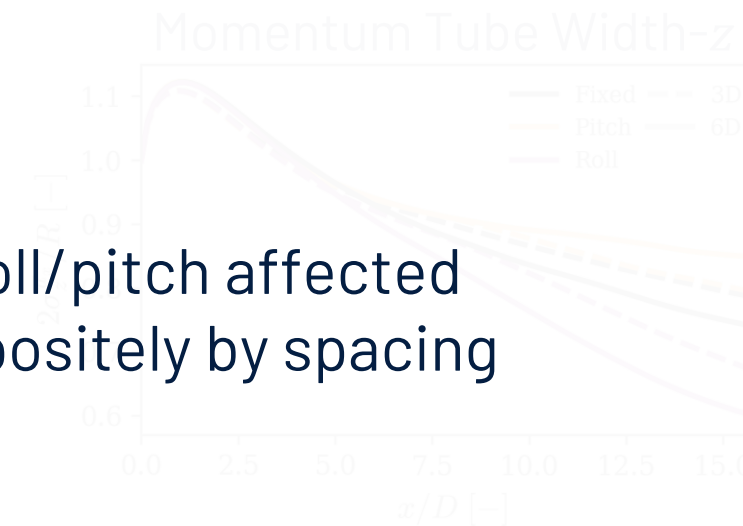

Conclusions

Conclusion

1. Performed transport tube analysis on the wakes of floating turbines subject to different inflows and turbine spacings
2. Uniform conditions:
 - ⚙️ Significantly impact transport/entrainment of momentum
3. In turbulent conditions:
 - ⚙️ Tube areas becomes largely insensitive
 - ⚙️ **Tube position/width remains dependent on platform motions**

Impact on wake models?

Impact on farm spacing?

Impact on AEP?

Acknowledgements



Chris Vogel
Supervision



Markella Zormpa
Supervision



Tim Rafferty
Inflow Generation
Methodology



Environmental Fluid
Mechanics Group



Thank you for listening

Questions?

Local Blockage

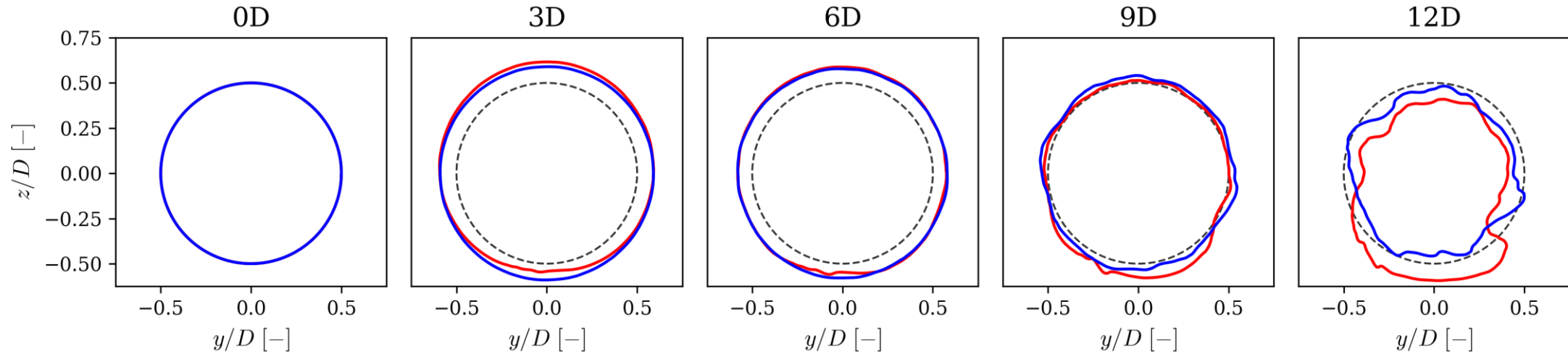

— Without Local Blockage — With Local Blockage

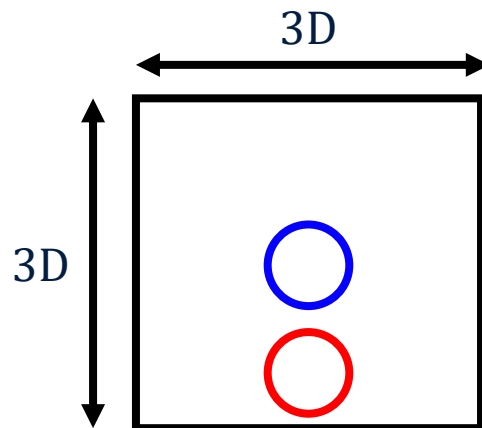

Mass Tube / Momentum Tube Area Ratio

Uniform inflow

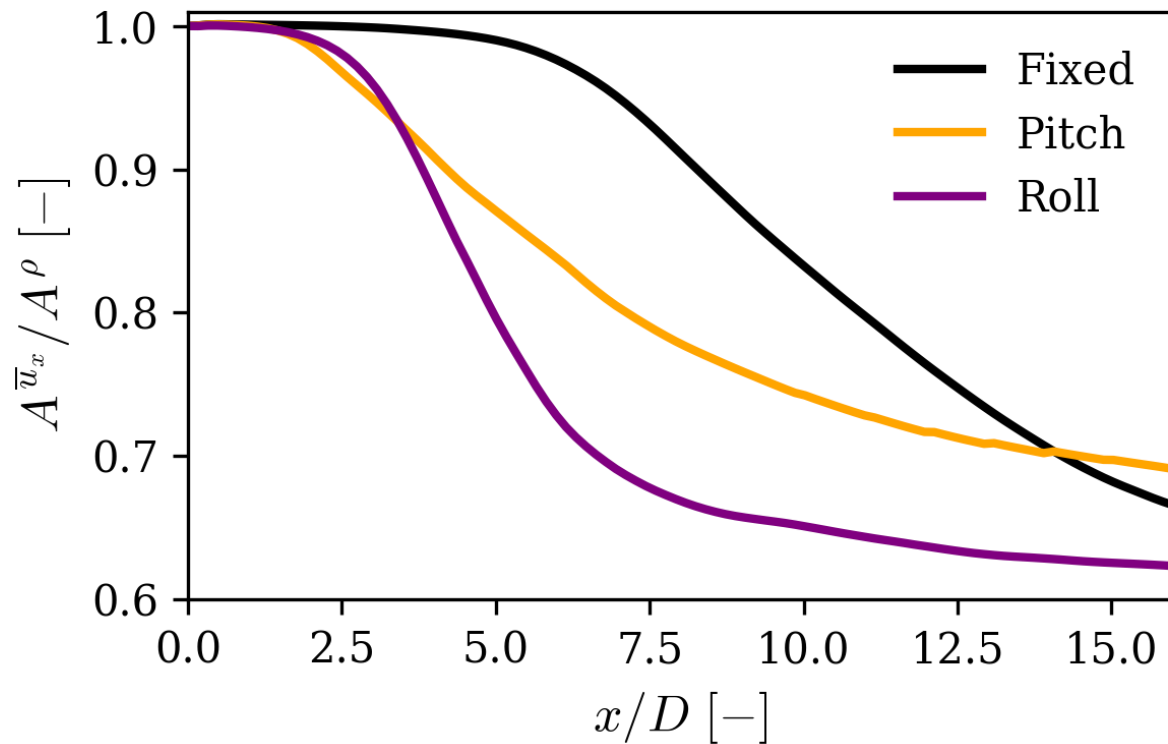

Turbulent inflow

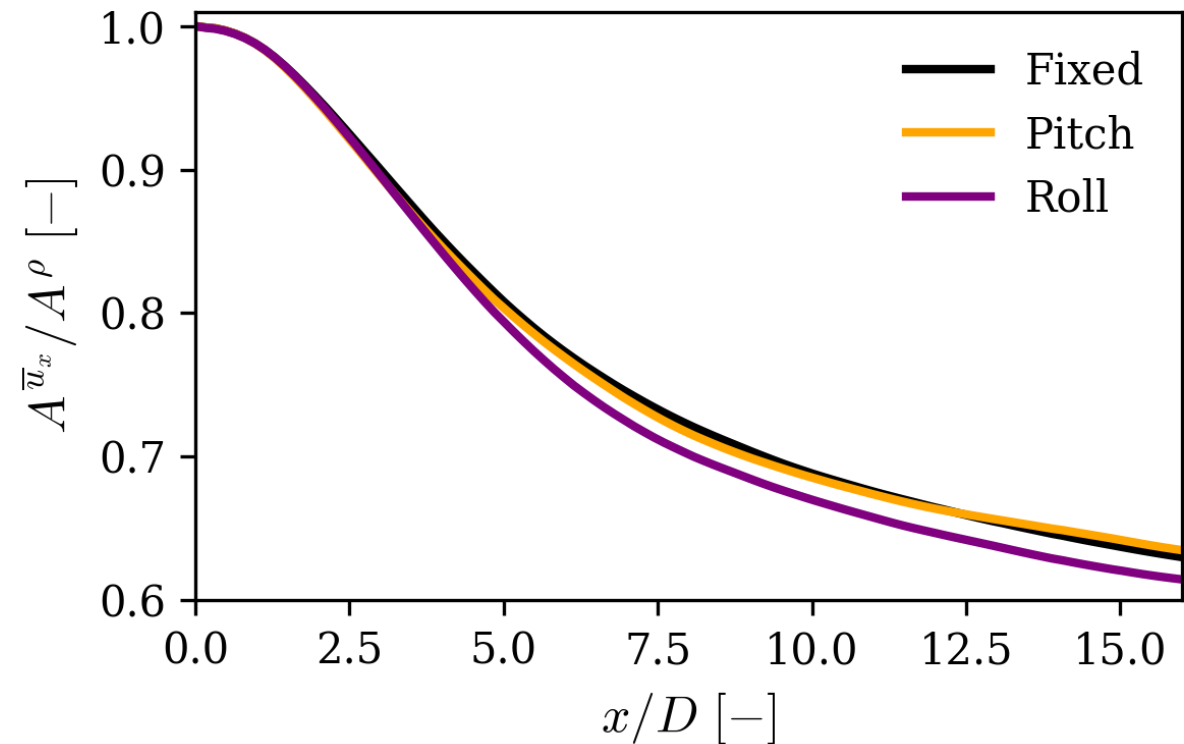

Uniform Pitching

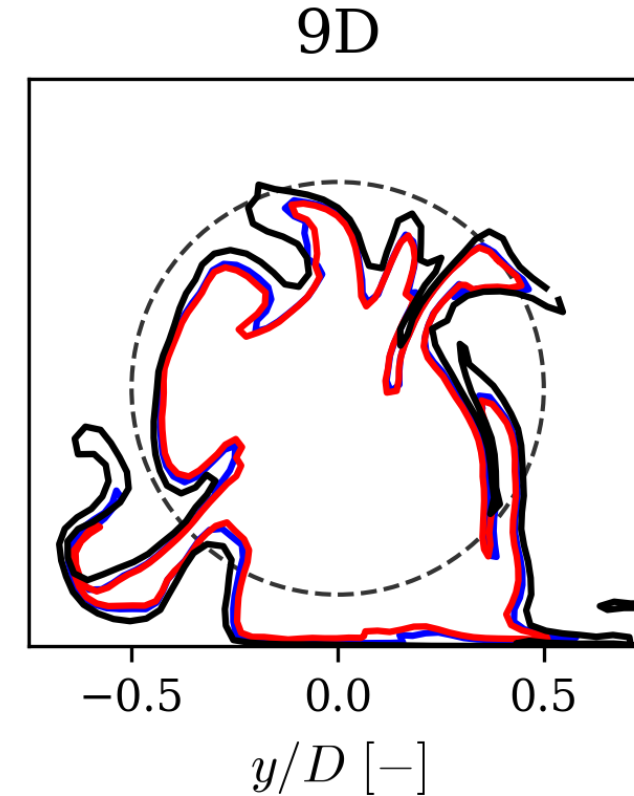
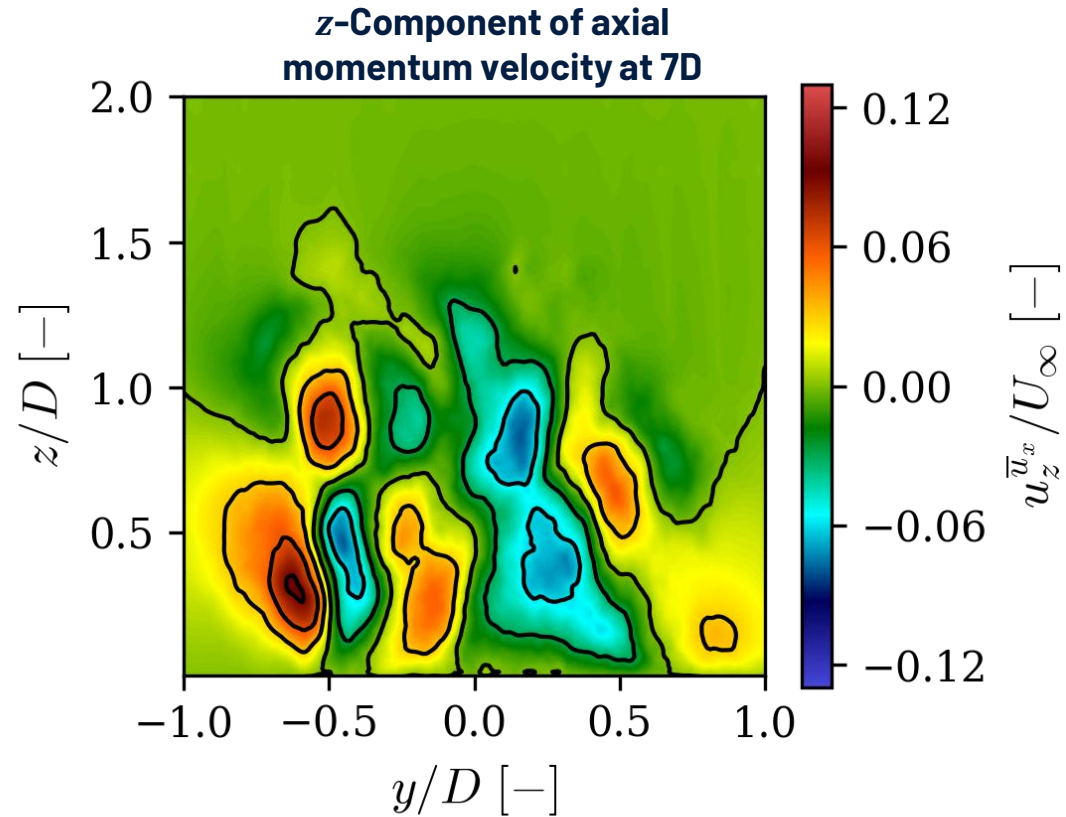

— Mass — Axial Momentum — Mechanical Energy

Thoughts on Limitations

1. **Cyclic conditions + prescribed motions = assumed phase between neighbours.**
2. **Seeding of tubes is based on fixed rotor position.**
3. **How to extend to deep-array effects while using prescribed motions.**
4. ...

